

FlowCon S



Installation
Operation
Commissioning



FlowCon S

Contents:

	Technical data and functional survey	2
1.	Installation	3
2.	Filling and flushing the system	4
3.	Draining the system	5
4.	Non-return valve	5
5.	Safety device	5
6.	Expansion tank connection set	5

Solar pump group with integrated Controller

The delivery involves:

DeltaSol[®] BS
or DeltaSol[®] BS Pro Controller

- Dial thermometer for flow
- Security device with safety valve and manometer
- Filling and emptying unit
- Wall mounting with screws and dowels
- Heat insulation

Technical data

Material:

Fittings: brass
Flat gaskets: Klingerit, max. 200°C
O-ring-seal: VITON/EPDM, max. 180°C
Solar non-return valve: PPS, max. 180°C
Insulation: EPP, max. 120°C,
at short term to 180°C

Admissible max. temperature:

0-120°C, at short term to 180°C

Dimensions:

with insulation: 500 x 230 x 62 mm

distance axis / wall: 62 mm

Mounting: wall mounting

Connections: ¾" F

Circulation pump: WILO Star ST20/6
or ST 20/7

Power supply: 210-250 V ~

Working pressure: max. 8 bar

Spring pressure of non-return valve:

200 mm water column

Flowmeter: 0,5-5 l/min.

1-13 l/min. (standard) or 8-30 l/min.



1. Installation

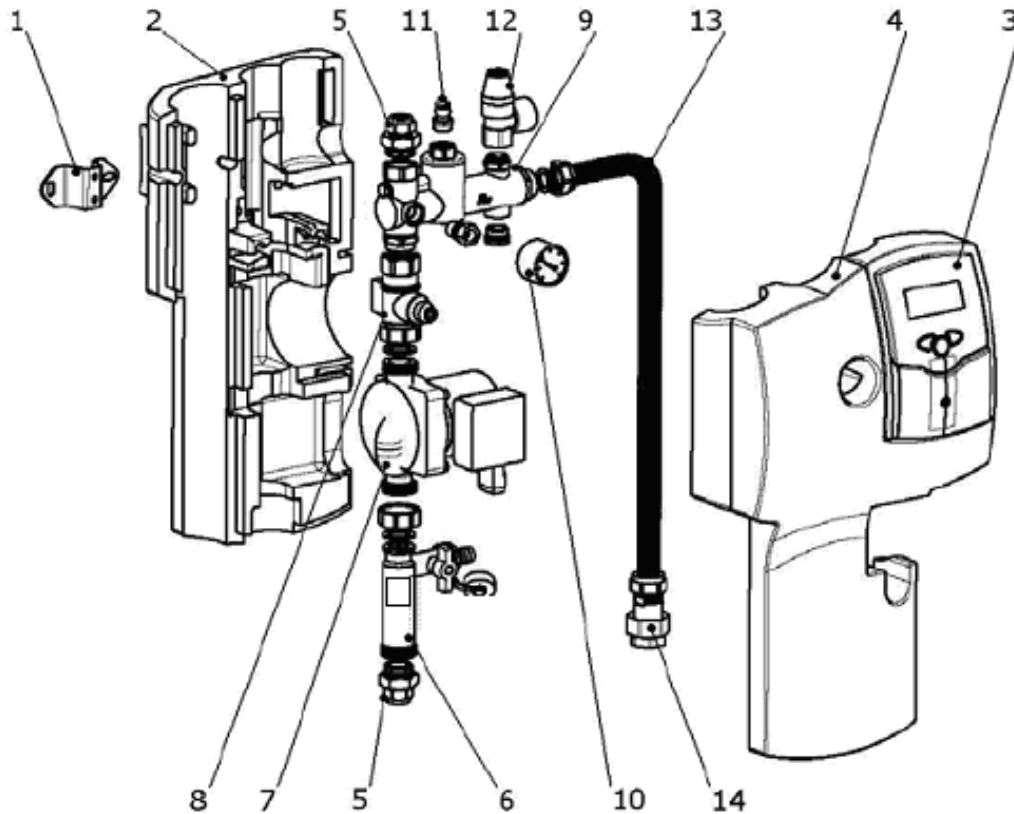

- | | |
|---|---|
| 1 - wall mounting | 8 - ball valve with integrated non-return valve (wrench-operated) |
| 2 - insulation - rear side | 9 - security-head piece with filling valve |
| 3 - Controller | 10 - solar manometer 0-6 bar |
| 4 - insulation - front side | 11 - solar manual air discharge valve |
| 5 - pipe screw joints (not included) | 12 - solar safety valve 6 bar |
| 6 - flush valve (emptying valve) with flowmeter | 13 - stainless steel corrugated tube 3/4" F |
| 7 - pump | 14 - solar expansion tank screw joint |

Mounting the pump group

- Choose the place of mounting, unpack the whole pump group and take off the front insulation jacket.
- Let the solar station always screwed to the backside of the insulation jacket!
- Mark the bore holes through the insulation, drill with a 8 mm drill, put the enclosed dowels (S 8) into the bore holes.
- Fasten the complete solar station with the enclosed screws (S6 x 60 mm) to the wall. Use a suitable Phillips screwdriver!
- Mount the connecting pipework between the pump group, store and the collector and connect the expansion tank.

All the connections are checked and tightened so that normally a retightening is not necessary. However by commissioning the system all the connections have to be checked at tightness (pressure test).

2. Filling and flushing the system

- Connect the inlet hose to the filling valve under the safety valve and open the valve completely.
- Connect the outlet hose to the emptying valve at the flowmeter and open the valve completely.
- The slit of the regulating screw at the flowmeter has to be adjusted horizontally. Thus the integrated ball valve is closed. Open the non-return valve over the pump. Adjust the ball valve with the aid of a wrench in position of 45° (half opened, half closed).
- Fill sufficient solar fluid into a canister of a filling station (not included in full kit) and fill the solar system.
- Using the filling station flush the solar circuit at least 15 minutes. To get the air completely out of the system it is necessary to open shortly the regulation screw at the flowmeter (slit vertical).

The complete solar system must not be flushed with water. As a total emptying of the system is mostly not possible, there is a danger of frost damage.

- Close the emptying valve while the filling pump is running and increase the system pressure to approx. 5 bar. The system pressure can be read off at the manometer.
- Close the filling cock and switch off the pump of the filling valve, open the regulation screw (slit vertical).
- Bleed the system above the collectors until the solar fluid is free of bubbles. Increase the testing pressure to approx. 5 bar again and check the tightness of system.
- Adjust the system pressure according to general instructions of the manufacturer of the collectors.
- Start the circulation pump at its maximum pump speed (see manual of the pump) and let it pump for at least 15 minutes.
- Afterwards bleed the system and adjust the pump speed to the desired speed.
- Adjust the volume flow at the flowmeter according to the general instructions of the collectors manufacturer (1-2 l to one flat collector).
- Remove the hoses of the filling station and screw caps to the filling station's cocks.
- Re-check the system again for tightness. Open the ball valve above the pump completely.
- Mount the front insulation jacket to the pump group.

3. Draining the system

- Open the non-return valve in the ball valve above the pump (see the following advice).
- Open the air vent at the highest point of the system (above the collectors).
- Open the emptying valve at the lowest point of the system, if possible close by the store connection, or at the flush valve and pump.

4. Non-return valve

- The non-return valve of the pump group is integrated in the ball valve above the circulation pump. It has an opening pressure of 200 mm water column.
- In order to empty the system completely, the non-return valve has to be opened. The knob of the ball valve has to be turned into position of 45°. In this position the ball in the ball valve opens the non-return valve.
- In normal operation of the system the ball valve has to be completely opened.
- If a wrong circulation still occurs, the flow line has to be equipped with an additional non-return valve.

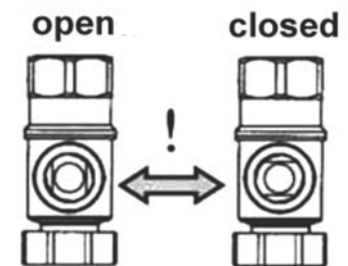

5. Safety device

The pump group is equipped with a solar-diaphragm security valve, which meets the relevant rules. The following instructions have to be considered during the installation and operation:

- The safety valve has to be well accessible. The efficiency of the valve must not be influenced or disabled by barriers!
- Place a vessel able to hold the complete volume of the liquid from the system under the safety valve outlet.

6. Expansion tank connection set

The expansion tank connection set consists of a stainless-steel corrugated pipe 0.5m long with cap nuts on both ends, flat gaskets and connection screw joints, and a mount strut for connecting an expansion tank.

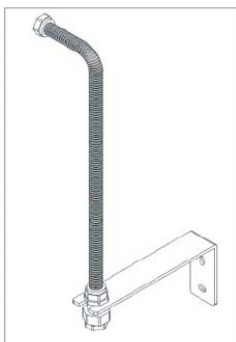

WARRANTY CERTIFICATE

WARRANTY CONDITIONS

1. The warranty period is 24 months from the date of purchase.
2. When claiming warranty, this Warranty Certificate must be submitted together with the purchase receipt.
3. The warranty is valid only when the technical conditions set by the Manufacturer, installation manual and instructions in the documentation and on the product itself are maintained.
4. The warranty does not cover defects caused by external conditions or improper operation conditions, defects caused by usual wear and tear, further when the product is not used in compliance with its purpose and when the defect was caused by:
 - mechanical damage to the product or its part
 - improper handling
 - tampering by a third person
 - improper installation
 - improper stocking
 - natural disaster

TIGHTNESS TEST CERTIFICATE

The system shall be filled with water, air-bled properly, pressurized to the test pressure of 5.5 bar and the whole system (all the connections, solar collectors, valves...) examined. No visible leaks may be observed. The system remains under pressure for at least 2 hours, after that it is re-examined.

The test result is considered successful when no leaks and/or no pressure depression are observed.

Date of Purchase:

Collector type:

Quantity:

Rubber stamp print and
signature of the seller:

Tightness test done and commissioned by:

Installation company:

VAT number:

Name of a responsible worker:

Tel:

Date:

Rubber stamp print and signature of the installer:



Regulus spol. s r.o.
Do Koutů 1897/3
143 00 Praha 4
Czech Republic

Tel.: +420 241 765 191
Fax: +420 241 763 976
e-mail: sales@regulus.cz
www.regulus.eu